

Dec. 27, 1938.

D. KAHN

2,141,988

PLAQUE HOLDER AND METHOD OF MAKING THE SAME

Filed March 30, 1937

3 Sheets-Sheet 1

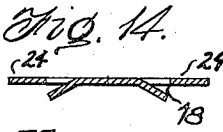
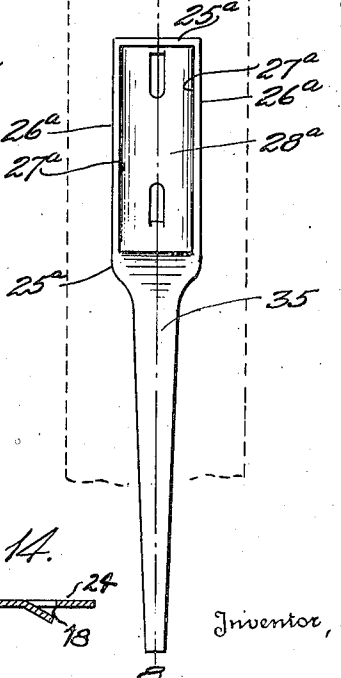
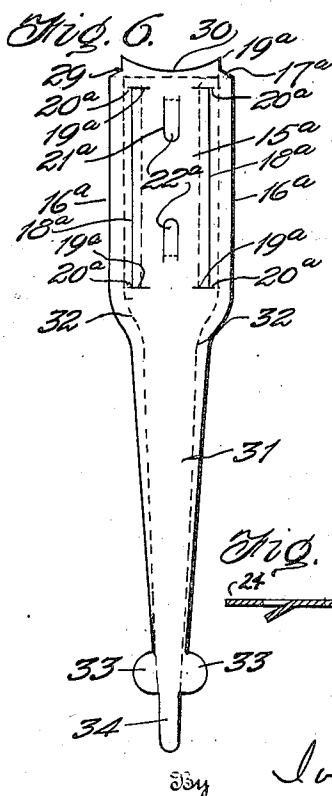
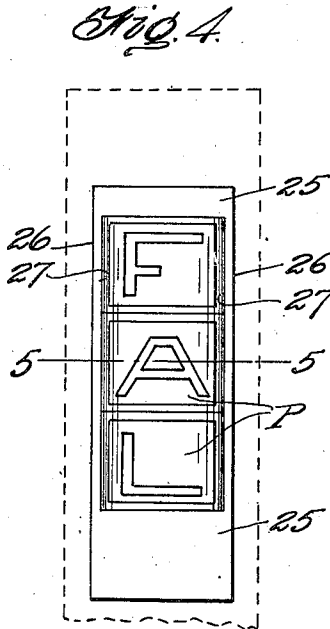
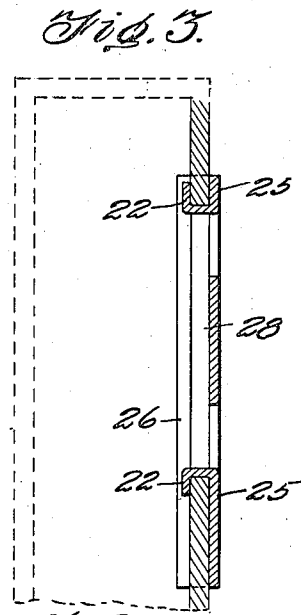
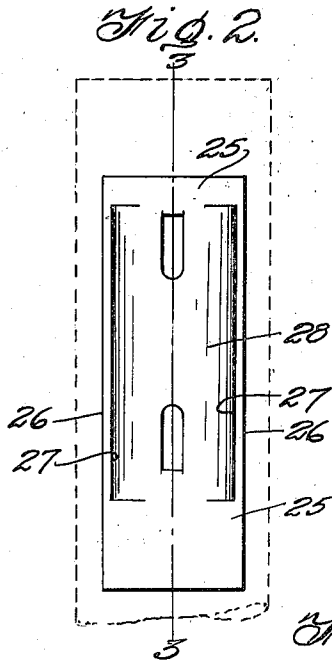
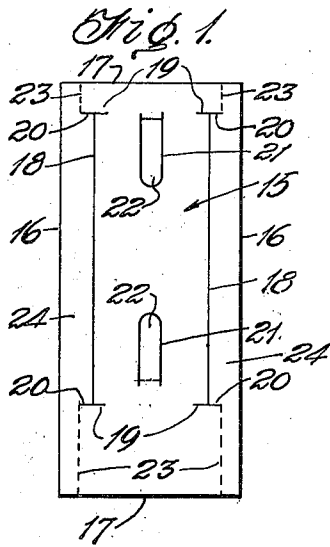

Inventor,
David Kahn
Ivan P. Tashof,
Attorney

Dec. 27, 1938.

D. KAHN

2,141,988

PLAQUE HOLDER AND METHOD OF MAKING THE SAME

Filed March 30, 1937

3 Sheets-Sheet 2

Fig. 8.

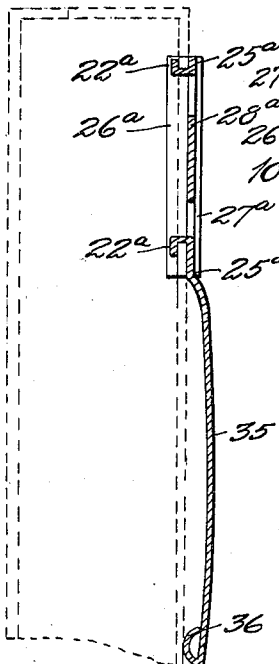

Fig. 9.

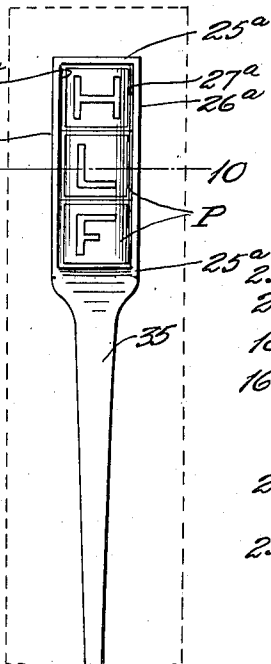

Fig. 11.

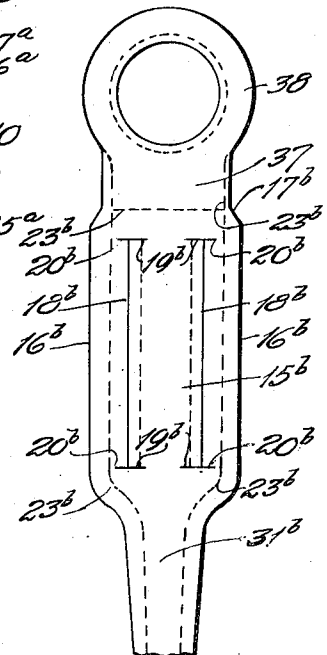

Fig. 12.

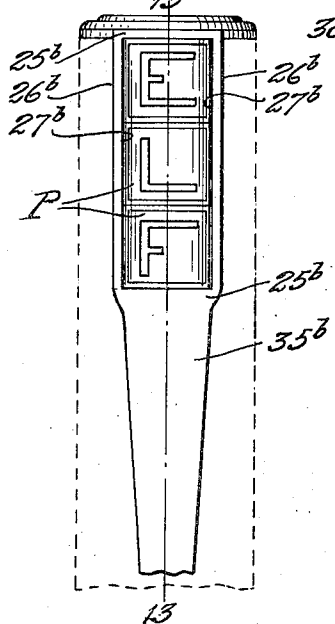

Fig. 13.

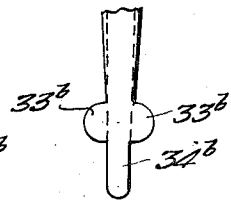
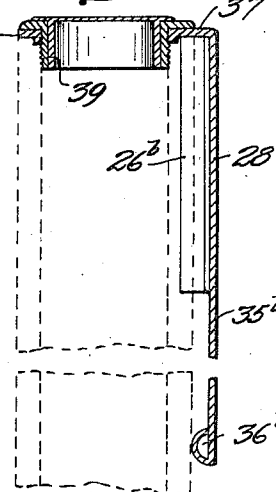
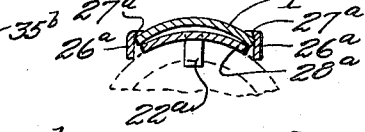

Fig. 10.



Inventor

David Kahn

By

Joan P. Tashof,

Attorney

Dec. 27, 1938.

D. KAHN

2,141,988

PLAQUE HOLDER AND METHOD OF MAKING THE SAME

Filed March 30, 1937

3 Sheets-Sheet 3

Fig. 15.

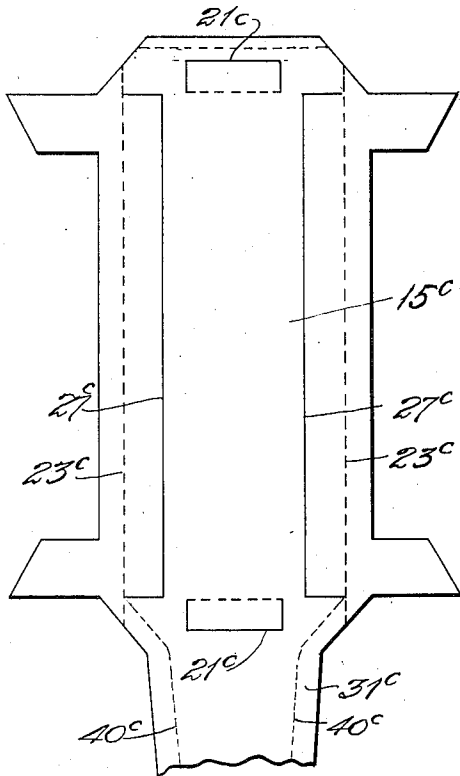

Fig. 16.

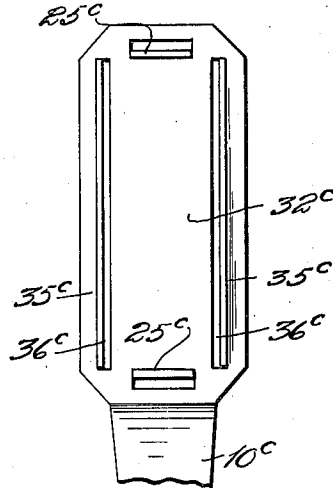

Fig. 17.

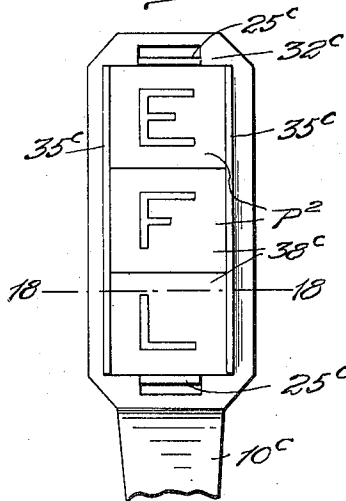
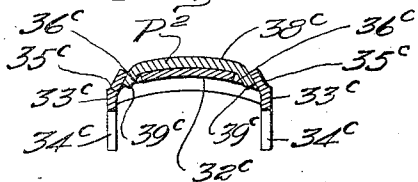

Fig. 18.



Inventor,

David Kahn

By

Ivan P. Tashof,
Attorneys

UNITED STATES PATENT OFFICE

2,141,988

PLAQUE HOLDER AND METHOD OF MAKING THE SAME

David Kahn, Woodcliff, N. J., assignor to David Kahn, Inc., Township of North Bergen, Hudson County, N. J., a corporation of New Jersey

Application March 30, 1937, Serial No. 133,913

22 Claims. (Cl. 40—140)

This invention relates to means for holding blocks or plaques having letters or other indicia or ornaments displayed thereon, the device being preferably termed a plaque holder.

The present application is a continuation-in-part of my prior application filed October 29, 1936, Serial No. 108,268, now Patent No. 2,094,796.

The invention also relates to the method of forming such plaque holders from sheet material and to blanks from which plaque holders are formed.

Furthermore, the invention relates to modifications and improvements in the plaque holding means disclosed in the application of David Kahn, for patent on Writing instrument clip, filed October 29, 1936, Serial No. 108,268, and the application of David Kahn for patent on Writing instrument clip, filed December 11, 1936, Serial No. 115,428, now Patent No. 2,094,797.

One important object of the invention is to provide an improved form of plaque holder wherein the construction is of extreme simplicity.

A second important object of the invention is to provide a novel and simple plaque holder formed from a single sheet metal stamping.

A third important object of the invention is to provide a novel and improved form of plaque holder and securing means therefor wherein the holder and securing means are formed integrally from a single sheet metal stamping.

A fourth important object of the invention is to provide a device of the kind set forth wherein the sheet metal employed in the formation of the article will have that character of resiliency which will allow the metal to yield or flex for the insertion of plaques and will cause it to spring back to normal form upon cessation of the stresses due to such plaque insertion.

A fifth important object of the invention is the provision of a novel sheet metal blank from which such plaque holders may be formed.

A sixth important object of the invention is the provision of a novel method of forming such plaque holders.

With the above and other objects in view, as will be presently apparent, the invention consists in general of a novel form of sheet metal blank for forming plaque holders, a novel method of effecting the formation of plaque holders from such blanks and also in certain novel details of construction and arrangement and formation of parts in the finished plaque holders as hereinafter fully described, illustrated in the accompanying drawings, and particularly pointed out in the claims.

In the accompanying drawings like characters of reference indicate like parts in the several views, and:—

Figure 1 is a plan view of the blank from which one form of the plaque holder is made.

Figure 2 is a face view of the formed plaque holder as applied to a writing implement, the plaques being omitted and the implement being indicated in dotted lines.

Figure 3 is a section on the line 3—3 of Figure 2.

Figure 4 is a view similar to Figure 2, but with plaques in position.

Figure 5 is a section on the line 5—5 of Figure 4.

Figure 6 is a plan view of the blank used in making a second form of the plaque holder.

Figure 7 is a view similar to Figure 2, but showing the second form of the invention.

Figure 8 is a section on the line 8—8 of Figure 7.

Figure 9 is a view similar to Figure 7, but with the plaques in position.

Figure 10 is a section on the line 10—10 of Figure 9.

Figure 11 is a plan view of the blank used in making a third form of the invention.

Figure 12 is a view similar to Fig. 2 but showing the third form of the invention.

Figure 13 is a section on the line 13—13 of Figure 12.

Figure 14 is a sectional view of a plaque holder blank showing a step during the method of stamping the article.

Figure 15 is a plan view of a portion of the blank of a still further modification of the invention.

Figure 16 is a face view of this form pressed to shape, the plaques being omitted.

Figure 17 is a face view with the plaques in place.

Figure 18 is a section on the line 18—18 of Figure 17.

In the form of the invention shown in Figures 1 to 5, the device is intended for attachment to any desired article. In this form the blank, indicated in general at 15, consists of an elongated, rectangular strip of thin sheet metal of a suitable grade of resiliency having side edge 16 and end edges 17. A pair of slits 18 are formed in the blank at equally spaced distances from the side edges 16. These slits 18 terminate at each end in spaced relation to the end edges 17, the slits preferably being spaced at a greater distance from one end edge than from the other. At each end of each slit 18 is a very short cross slit having an inwardly extending portion 19 and an outwardly extending portion 20, these

portions being of equal or substantially equal lengths. Located with their axes on the longitudinal median line of the blank is a pair of substantially U-shaped slits forming tongues 22 attached at one end to the metal of the blank.

In forming the plaque holder the end portions are bent on fold lines 23 extending from the outer ends of the slits 20 to the respective ends 17. This effects displacement of the portions 24 of the blank which lies between the slits 18 and the adjacent edges 16 so that the inner edges of this portion rise, while their outer edges 16 turn downwardly. Also, the narrow strips between the slits 19 at each side of the blank are flexed downwardly at their free edges formed by the slits 18. Upon the portions between the slits 18 and edges 16 being thus brought to right angles to their original positions, the top edges are beaded inwardly to a slight extent. Likewise, the tongues 22 are bent downwardly at right angles to their original positions. These operations may be performed simultaneously or in a succession of steps in an ordinary stamping and pressing machine well known to those skilled in the art.

When the blank is formed it will be seen that there is provided a plaque holder having a pair of flat ends 25 lying in the same plane. At each side of the holder is a vertical side wall 26 having an inwardly extending bead 27 at its upper edge. The top surfaces of these beads 27 lie substantially in the plane of the top surfaces of the ends 25. The portion between the ends 25 and side walls 26 forms a transversely arched saddle 28 having its sides spaced below the beads 27.

Obviously, instead of performing the steps of forming the blank in the manner as above described, the portions 24 of the blank may be turned down and the saddle 28 may then be stamped out along the slit line. In this way, the beads 27 will simply be formed by a portion of the top of the plaque holder. The manner of stamping the saddle 28 out of a plane surface may be seen in Figure 14. Although the saddle 28, as shown in Figure 14, is not shown as smoothly arched, as in the other figures of the drawings, Figure 14 is merely intended to illustrate a step in the method of stamping the saddle, and it is obvious that the saddle may be left as shown in Figure 14, or subsequently arched, as shown in the other figures of the drawings.

The plaques P used herewith are preferably of the transversely arched form and are of slightly greater width than the distance between the beads 27 so that when one side of a plaque P is inserted between a bead 27 and the portion of the saddle below the bead, the remaining side of the plaque will slightly overlap the other bead 27. Upon pressure downwardly being exerted on the free side of the plaque in this position, the sides of the holder will be so deformed as to allow this free side to snap downwardly to rest on the saddle side, the resiliency of the holder material causing the sides to assume normal position whereupon both sides of the plaque will be held between the beads 27 and side portions of the saddle as shown in Figure 5.

In the form of the invention shown in Figures 6 to 10 both inclusive, the plaque holder is shown as combined with a clip such as is commonly used on pens, pencils and the like to hold the article in a user's pocket.

In this form, the blank has a body portion 15a of elongated rectangular form and this blank

body is constructed in a manner analogous to the blank of the first form, the proportions of the elements being somewhat different. These parts are accordingly given like reference characters, the corresponding characters being given the suffix "a". It will be noted, especially that the slits 19^a are considerably longer than the slits 20^a. This gives the saddle a slightly different and deeper form.

In this form the upper end of the blank is provided with an extension 29 having a concavely curved outer edge 30. The other or lower end of the body is provided with a tapered clip extension 31 having side portions defined from the body 15^a by fold lines 32. At the outer extremity, this extension 31 is provided with oppositely disposed lateral semi-circular lugs 33 and from these lugs extends a tongue 34.

In this form the body is shaped as in the previous form, but the extension 29 is turned downwardly and the sides of the extension 31 are arched downwardly. The sides of the plaque holder and the clip are formed by bending along the line 32. The lugs 33 are bent down in parallelism and the tongue 34 arched downwardly and backwardly to lie between the lugs 33 and conform to the outline thereof.

The formed body has its parts indicated by the characters used with the first form with the suffix "a". However, this form of the complete device provides an elongated clip arm 35 having a gripping boss 36 on the under side of its extremity.

In the form of the device shown in Figures 11, 12 and 13, the construction of the blank and the completed article is, in many respects, analogous to the previous forms. Accordingly, corresponding parts have been given corresponding reference numerals, each being provided with the suffix "b". However, in this form, the extension is replaced by an extension 37 carrying a ring 38. In forming the complete article the extension 37 and ring 38 are bent at right angles to the body and a screw threaded ferrule 39 is fitted in the ring so that the device can be screwed in the upper end of a pen cap or the like. A cap member not designated by reference numeral is held within the ferrule in any suitable manner. In each of the last two forms the plaques P are applied as in the first form.

In the form of the device shown in Figures 15 to 18, the blank is made with a body portion 15^c and tongue portion similar to the tongue 31, the part shown being indicated at 31^c. This blank is provided with U-shaped end slots 21^c providing end stops 25^c by turning up the metal as shown in Figure 16. The blank is also provided with U-shaped slots 27^c running along each side of the blank and by bending the portions thus defined upwardly along the fold lines 23^c and the marginal portions downwardly, a plaque receiving structure is formed, a clip body plate 32^c having depending side flanges 33^c provided with prongs 34^c and upwardly and inwardly converging side flanges 35^c overhanging slots 36^c. Plaques P2 are provided for this form which have each a body portion 38^c provided with narrow and outwardly flaring side flanges 39^c. The plaques in this arrangement are snapped into place by downward pressure in a manner similar to that previously described in connection with other modifications. A tongue 10^c is formed from the blank portion 31^c by bending the same along the lines 40^c.

In the preferred embodiment, the initial

plaques are formed of relatively stiff enameled sheet metal. Otherwise, any great amount of flexing would be liable to crack the enamel. However, these plaques may be made of Bakelite or some other relatively rigid material. Obviously, if the plaques are made in order to permit a certain amount of flexing, the plaque holder does not have to be made of relatively flexible spring metal. The only criterion is that the plaques and plaque holder should be capable, respectively, of some deformation in order that the plaques may be inserted and held securely therein.

I claim:—

1. That method of forming plaque holders which consists in forming a blank of sheet metal with a substantially rectangular body, producing a pair of parallel slits extending longitudinally of the body in spaced relation to the longitudinal edges of said body, said slits having cross slits at their ends, said slits terminating at each end in spaced relation to the ends of the body, bending the portions defined by said slits downwardly to form a saddle-like central portion in said body, bending the side edge portions of the body downwardly.

2. A thin sheet metal blank for a combination plaque holder and clip including a body of elongated rectangular form having side edges and end edges, said blank having a pair of spaced longitudinal slits and a short transverse slit at each end of each longitudinal slit and extending laterally from the longitudinal slits, and means adapted to form a clip portion.

3. A thin sheet metal blank for a combined plaque holder and clip including a body of elongated rectangular form having side edges and end edges, said blank having a pair of spaced longitudinal slits and a short transverse slit at each end of each longitudinal slit and extending inwardly from said longitudinal slits, the portion of the blank removed from the slitted portion being provided with oppositely disposed lateral lugs, and a tongue extending between said lateral lugs.

4. A thin sheet metal blank for plaque holders including a body of elongated rectangular form having side edges and end edges, said blank having a pair of longitudinal slits parallel to the side edges of the blank and spaced equally from the respective side edges, said blank having a short transverse slit at each end of said longitudinal slit and extending inwardly and outwardly from the longitudinal slits.

5. A thin sheet metal blank for plaque holders including a body of elongated rectangular form having side edges and end edges, said blank having a pair of longitudinal slits parallel to the side edges of the blank and spaced from the respective side edges, said blank having a short transverse slit at each end of said longitudinal slit, and means thereon for forming integral attaching members.

6. A plaque holder comprising a single sheet metal structure having an elongated body provided with a central saddle portion arcuate in cross-section and terminating at each end in spaced relation to the body end, said saddle portion being in a different plane than the remainder of said elongated body so as to form a seat and end stops for plaques, said body having vertical side walls extending downwardly to a plane below the side edges of the saddle and extending upwardly therefrom, said side walls having inwardly extending beads at their upper edges.

7. A plaque holder comprising a single sheet metal structure having an elongated body provided with a central saddle portion arcuate in cross-section and terminating at each end in spaced relation to the body end, said saddle portion being in a different plane than the remainder of said elongated body so as to form a seat and end stops for plaques, said body having vertical side walls extending downwardly to a plane below the side edges of the saddle and extending upwardly therefrom, said side walls having inwardly extending beads at their upper edges, and attaching means extending downwardly from said body.

8. A plaque holder comprising a single sheet metal structure having an elongated body provided with a central saddle portion arcuate in cross-section and terminating at each end in spaced relation to the body end, said body having vertical side walls extending downwardly to a plane below the side edges of the saddle and extending upwardly therefrom, said side walls having inwardly extending beads at their upper edges, and attaching tongues formed from the material of the body at its longitudinal median line and extending downwardly from the body.

9. A plaque holder comprising a single sheet metal structure having an elongated body provided with a central saddle portion arcuate in cross-section and terminating at each end in spaced relation to the body end, said saddle portion being in a different plane than the remainder of said elongated body so as to form a seat and end stops for plaques, said body having vertical side walls extending downwardly to a plane below the side edges of the saddle and extending upwardly therefrom, said side walls having inwardly extending beads at their upper edges.

10. A plaque holder comprising a single sheet metal structure having an elongated body provided with a central saddle portion arcuate in cross-section and terminating at each end in spaced relation to the body end, said saddle portion being in a different plane than the remainder of said elongated body so as to form a seat and end stops for plaques, said body having vertical side walls extending downwardly to a plane below the side edges of the saddle and extending upwardly therefrom, said side walls having inwardly extending beads at their upper edges, said body having its ends lying in the same plane with the sides of the saddle below the plane of the ends, the upper surfaces of the beads lying in the plane of the upper surfaces of said ends so as to retain said plaques between said beads and said saddle.

11. A plaque holder comprising a single sheet metal structure having an elongated body provided with a central saddle portion arcuate in cross-section and terminating at each end in spaced relation to the body end, said saddle portion being in a different plane than the remainder of said elongated body so as to form a seat and end stops for plaques, said body having vertical side walls extending downwardly to a plane below the side edges of the saddle and extending upwardly therefrom, said side walls having inwardly extending beads at their upper edges, and attaching means extending downwardly from said body.

12. A plaque holder comprising a single sheet metal structure having an elongated body provided with a central saddle portion arcuate in cross-section and terminating at each end in spaced relation to the body end, said body having

vertical side walls extending downwardly to a plane below the side edges of the saddle and extending upwardly therefrom, said side walls having inwardly extending beads at their upper edges, said body having its ends lying in the same plane with the sides of the saddle below the plane of the ends, and attaching tongues formed from the material of the body at its longitudinal median line and extending downwardly from the body.

13. A plaque holder comprising a single sheet metal structure having an elongated body provided with a central saddle portion arcuate in cross-section and terminating at each end in spaced relation to the body end, said body having vertical side walls extending downwardly to a plane below the side edges of the saddle and extending upwardly therefrom, said side walls having inwardly extending beads at their upper edges, said body having its ends lying in the same plane with the sides of the saddle below the plane of the ends, the upper surfaces of the beads lying in the plane of the upper surfaces of said ends, and attaching means extending downwardly from said body.

14. A plaque holder comprising a single sheet metal structure having an elongated body provided with a central saddle portion arcuate in cross-section and terminating at each end in spaced relation to the body end, said body having vertical side walls extending downwardly to a plane below the side edges of the saddle and extending upwardly therefrom, said side walls having inwardly extending beads at their upper edges, said body having its ends lying in the same plane with the sides of the saddle below the plane of the ends, the upper surfaces of the beads lying in the plane of the upper surfaces of said ends, and attaching tongues formed from the material of the body at its longitudinal median line and extending downwardly from the body.

15. In combination, a plaque holder having a body portion provided along its sides with a pair of U-shaped slits and having the material defined by the slits extending upwardly and inwardly to form converging side flanges, interchangeable plaques each having a body and diverging side flanges engageable beneath the first mentioned flanges, and means on the holder to prevent longitudinal movement of the plaques on the holder.

16. In combination, a plaque holder having a body portion provided along its sides with a pair of U-shaped slits and having the material defined by the slits extending upwardly and inwardly to form converging side flanges, interchangeable plaques each having a body and diverging side flanges engageable beneath the first mentioned flanges, and stop flanges on the holder at the ends of the assembled plaques.

17. A combination plaque holder and article clip having a relatively resilient clip portion and a body portion provided along its sides with a pair of U-shaped slits and having the material adjacent the slits bent out of the plane of the body, interchangeable plaques each having a body and side portions, the side portions of the plaques being constructed and arranged for interlocking

engagement upon the plaques being positioned on the body between the bent portions and the body.

18. In combination, a plaque holder having a body portion provided along its sides with a pair of U-shaped slits and having the material adjacent the slits bent out of the plane of the body, interchangeable plaques each having a body and side portions, the side portions of the plaques being constructed and arranged for interlocking engagement upon the plaques being positioned on the body between the bent portions and the body, and means at the ends of the holder body engaging certain of the plaques and holding them against longitudinal movement.

19. In combination, a plaque holder having a body portion provided along its sides with a pair of U-shaped slits and having the material adjacent the slits bent out of the plane of the body, interchangeable plaques each having a body and side portions, the side portions of the plaques being constructed and arranged for interlocking engagement upon the plaques being positioned on the body between the bent portions and the body, and a clip tongue projecting from one end of said holder.

20. In combination, a plaque holder having a body portion provided along its sides with a pair of U-shaped slits and having the material adjacent the slits bent out of the plane of the body, interchangeable plaques each having a body and side portions, the side portions of the plaques being constructed and arranged for interlocking engagement upon the plaques being positioned on the body between the bent portions and the body, means at the ends of the holder body engaging certain of the plaques and holding them against longitudinal movement, and a clip tongue projecting from one end of said holder.

21. A combination clip and plaque holder for instruments formed of a single integral piece of sheet metal, comprising a plaque holding portion and an elongated relatively resilient clip portion, and means for attaching said combination plaque holder and clip to an instrument, said last mentioned means extending from one of said portions and being constructed and arranged to extend into and be permanently secured to said instrument, said plaque holding portion having an opening therein forming a retaining seat for an initial plaque, and means to retain said initial plaque in said seat.

22. A combination clip and plaque holder for instruments formed of a single integral piece of sheet metal, comprising a plaque holding portion and an elongated relatively resilient clip portion, and means for attaching said combination plaque holder and clip to an instrument, said last mentioned means extending from one of said portions and being constructed and arranged to extend into and be permanently secured to said instrument, said plaque holding portion having a portion thereof struck out of the plane of the plaque holding portion to form a retaining seat for an initial plaque, and means to retain an initial plaque in said seat.

DAVID KAHN.