

March 2, 1954

F. R. WITNEBERT

2,670,711

FOUNTAIN PEN

Filed Sept. 13, 1947

5 Sheets-Sheet 2

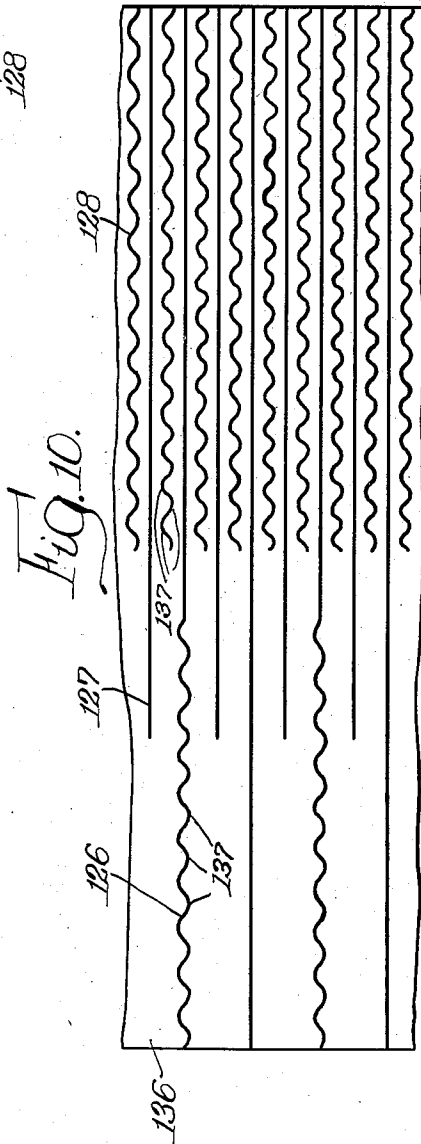
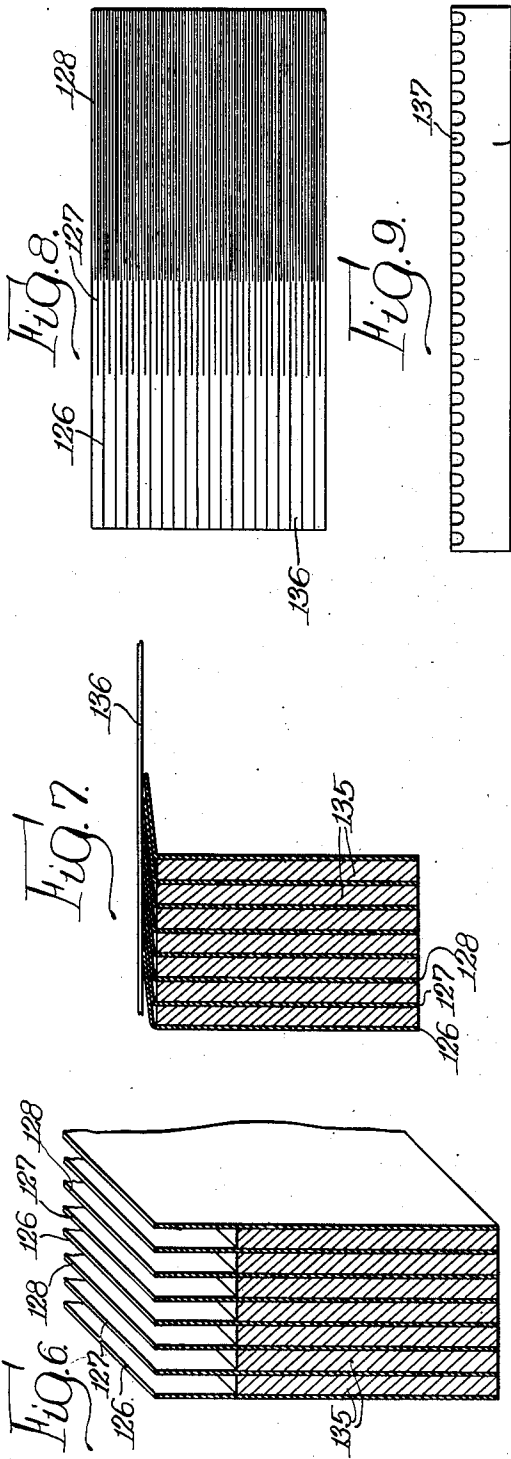

INVENTOR,
Frederick R. Wittnebert,
BY
Hidley, Crowe & Beardsley
Attys.

March 2, 1954

F. R. WITNEBERT

2,670,711

FOUNTAIN PEN

Filed Sept. 13, 1947

5 Sheets-Sheet 3

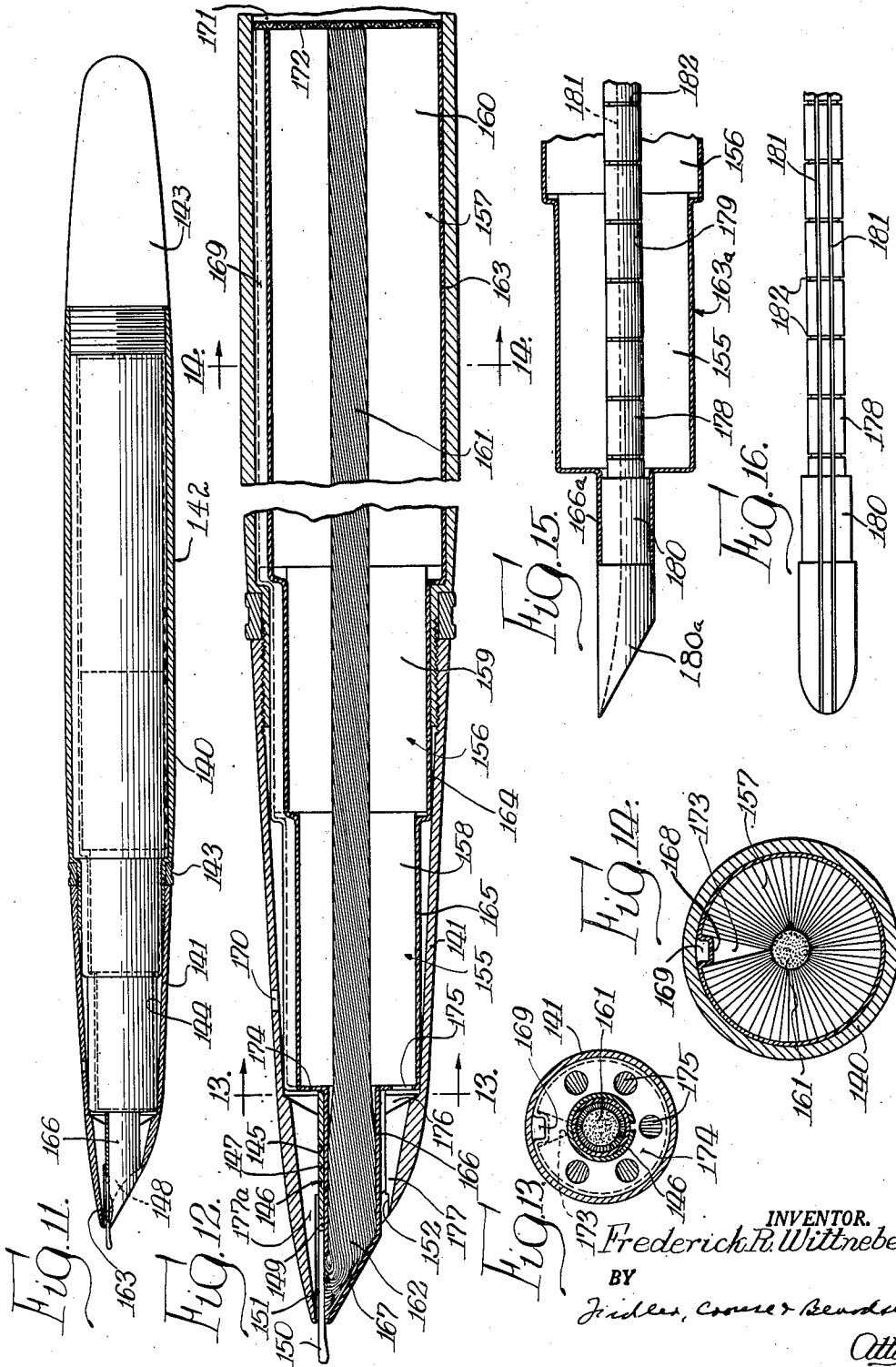

INVENTOR.
Frederick R. Wittnebert,
BY
Fideler, Coover & Beardsley
Attys.

March 2, 1954

F. R. WITNEBERT

2,670,711

FOUNTAIN PEN

Filed Sept. 13, 1947

5 Sheets-Sheet 4

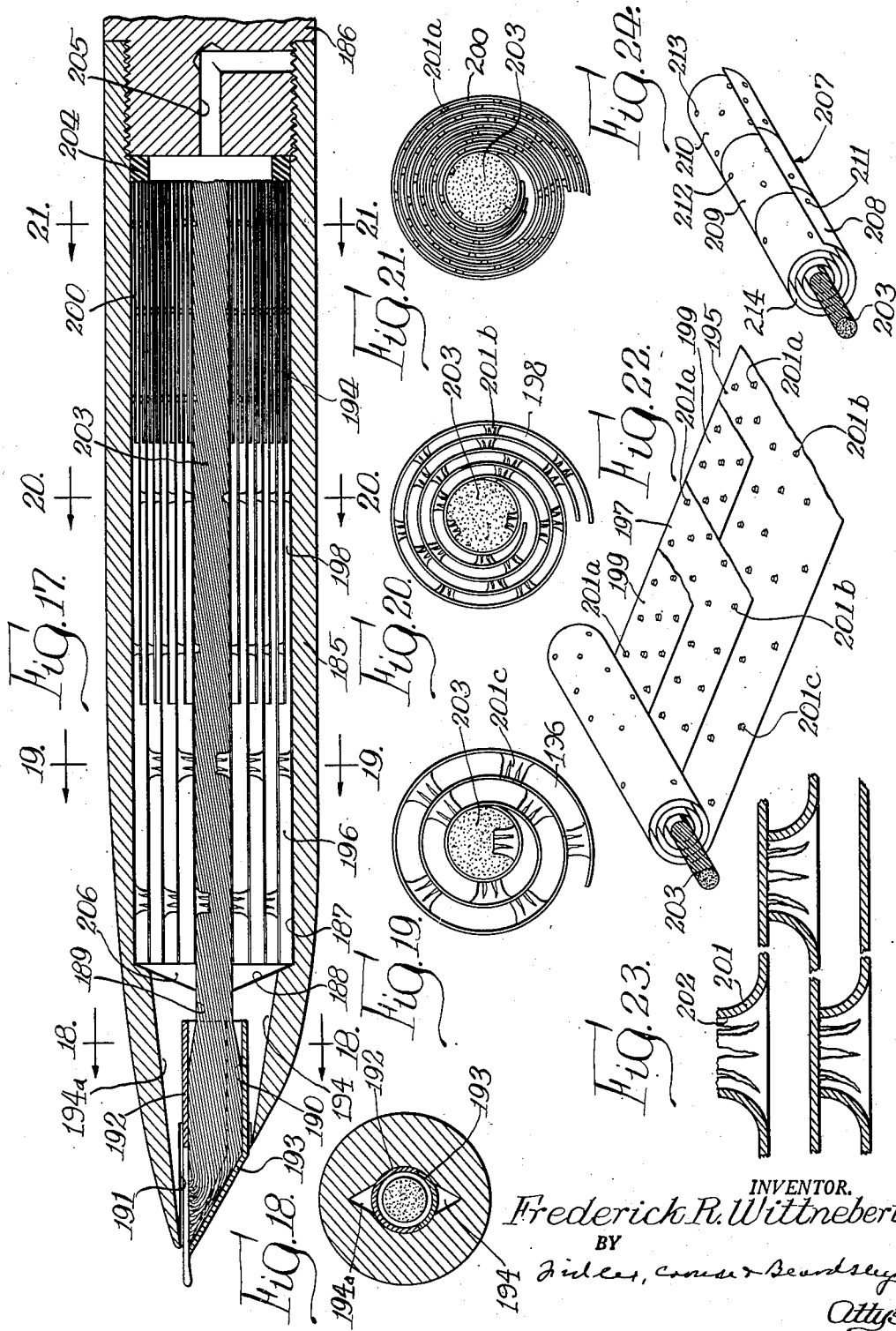

INVENTOR,
Frederick P. Wittnebert,
BY
Fishes, Connor & Beardsey
Attys.

UNITED STATES PATENT OFFICE

2,670,711

FOUNTAIN PEN

Frederick R. Wittnebert, Chicago, Ill., assignor to
The Parker Pen Company, Janesville, Wis., a
corporation of Wisconsin

Application September 13, 1947, Serial No. 773,815

21 Claims. (Cl. 120—50)

1

My invention relates to fountain pens and has to do particularly with fountain pens of the type wherein the ink reservoir is adapted to be filled by capillary action, the ink is held in the reservoir by capillary action and the ink is fed therefrom by capillary action to a writing surface when the pen is used in writing.

One of the objects of my invention is to provide an improved fountain pen of the foregoing character.

Another object is to provide an improved filling and ink feeding means for a fountain pen of the foregoing character.

A further object is to provide a fountain pen of the capillary filling type having a filler element defining a plurality of capillary ink storage spaces or cells, and wherein the cell-forming members occupy a minimum portion of the total volume of the ink reservoir space, thereby providing a maximum volume of ink storage capacity for an ink reservoir space of any overall size.

A further object is to provide a fountain pen of the capillary type having a plurality of capillary ink storage spaces or cells extending longitudinally of the pen and formed with a greater capillarity at the portion thereof more distant from the writing end of the pen than at the portion nearer to the writing end of the pen.

Still another object is to provide a capillary filler element for a fountain pen having a plurality of capillary spaces or cells extending longitudinally thereof and so formed that the capillarity of the spaces at the various portions of the filler element corresponds generally with the distance of such portions from the writing end of the pen.

Another object of the invention is to provide an improved fountain pen of the type described having a relatively large refill and write-out capacity.

Other and more specific objects of the invention are to provide: a fountain pen having a capillary filler element wherein the capillarity thereof is graded longitudinally thereof and which can be readily and accurately predetermined and maintained; a fountain pen having a readily removable cartridge including a capillary filler element and feed inclosed and formed as a unit with a protective cartridge casing; a fountain pen of the capillary type having an improved venting means for maintaining the interior substantially at atmospheric pressure; an improved method of forming a capillary filler element; an improved arrangement for substantially closing the writing end of the pen body; an improved arrangement for maintaining a wick-like feed element in ink feeding relation to the nib of the pen; a novel arrangement for maintaining a series of fin-like partitions in predetermined, spaced relation to define a plurality of capillary ink storage spaces

2

or cells; and a simple and readily assembled structure for providing capillary cells of graded sizes.

Other objects of the invention will appear from the following description taken in connection with the appended drawings wherein:

Figure 1 is a fragmentary view, partially in longitudinal cross-section, of a fountain pen constructed in accordance with my invention;

Figure 2 is an exploded perspective view of a nib and an end closure member forming a portion of the pen shown in Figure 1;

Figure 3 is a transverse, cross-sectional view taken along line 3—3 of Figure 1;

Figure 4 is a transverse, cross-sectional view taken along line 4—4 of Figure 1;

Figure 5 is a side elevational view of a capillary filler element and feed element forming a portion of the pen shown in Figure 1;

Figure 6 is an enlarged, fragmentary and somewhat diagrammatic view illustrating the arrangement of the fin-forming strips in one step in the formation of the capillary filler element;

Figure 7 is a diagrammatic view of the fin forming strips as they appear after bending and application of the backing sheet;

Figure 8 is a reduced top plan view of the assembly of fin forming strips and backing sheet prior to rolling into final form;

Figure 9 is a side elevational view of the assembly of Figure 8;

Figure 10 is an enlarged, fragmentary, and somewhat diagrammatic top plan view of a portion of the structure shown in Figure 8;

Figure 11 is a longitudinal view partially in cross section of a pin embodying a modified form of my invention;

Figure 12 is an enlarged, fragmentary, longitudinal sectional view of a portion of the structure shown in Figure 11;

Figure 13 is an enlarged, transverse cross-sectional view taken along line 13—13 of Figure 12;

Figure 14 is an enlarged, transverse cross-sectional view taken along line 14—14 of Figure 12;

Figure 15 is a fragmentary view, partially in cross-section showing the forward end of a cartridge generally similar to the cartridge of Figure 11 only employing a modified form of feed member;

Figure 16 is a top plan view of the feed member shown in Figure 15;

Figure 17 is a fragmentary, longitudinal, sectional view of a pen embodying still a further form of my invention;

Figure 18 is a transverse sectional view taken along line 18—18 of Figure 17;

Figure 19 is a transverse sectional view taken along line 19—19 of Figure 17;

Figure 20 is a transverse sectional view taken along line 20—20 of Figure 17;

Figure 21 is a transverse sectional view taken along line 21—21 of Figure 17;

Figure 22 is a reduced, fragmentary and somewhat diagrammatic view showing the capillary filler element of the pen of Figure 17 in its condition during assembly thereof;

Figure 23 is an enlarged, fragmentary, transverse sectional view through the capillary filler element of Figure 22 and showing particularly the manner of spacing consecutive turns of the sheets forming the filler element;

Figure 24 is a perspective view showing a slightly modified form of capillary filler element comprising three separate longitudinally abutting sections;

Fig. 25 is a fragmentary and somewhat diagrammatic view of a modified form of filler element made from a single sheet, in an initial step in forming the filler element;

Fig. 26 is an enlarged longitudinal cross-sectional view of a portion of the filler element of Fig. 25; and

Fig. 27 is a view similar to Fig. 17 only showing a pen embodying the filler element of Fig. 25.

The fountain pen of the present invention may be made as a pocket pen having the usual cap or it may be made as a desk pen having the usual elongated tailpiece, or if desired it may be made as a convertible pen which can be used either as a pocket pen or a desk pen.

Referring now particularly to Figure 1 of the drawings, the pen includes a pen body or barrel including a front section 100 and a rear section 101, detachably connected to the front section as by a threaded joint 102. The body may be formed of any suitable material such as metal or a plastic and preferably is formed from a plastic such as "Lucite" (methyl methacrylate resin). The forward body section 100, which preferably terminates at its forward end in a tapered portion 103, is formed with a bore 104 extending longitudinally therethrough and opens to the exterior of the pen in a forward opening 105.

Carried at the forward end of the pen body is a writing element which preferably takes the form of a pen nib 106. The pen nib 106 (Figure 3) has the general form of a portion of a cone and at its rear end is provided with a split ring portion 107 adapted to resiliently and frictionally engage against a tapered portion 108 of the bore and to bear against a shoulder 109 for the purpose of positioning the nib within the forward end of the body with only the forward writing tip projecting therefrom. The nib 106 is formed with a slit 111 providing two flexible nib sections 112, and with a pierce 110 which registers with an air opening 115 formed in the upper wall of the forward pen body for a purpose which will hereinafter appear.

For the purpose of substantially closing the open forward end of the pen body and for retaining the feed element, hereinafter described, in ink feeding relation with the nib, an end piece or shoe 120 is provided which has a generally trough shaped body 121 adapted to fit into the tapered portion 108 of the bore forwardly of the nib 106. The edges of the body portion 121 are generally complementary in shape to the edges of the nib so that the end piece fits against the nib when these two members are in position in the pen body. The end piece is provided with a forward end wall 122 preferably inclined, as illustrated, and having its periphery conforming generally to the periphery of the opening 105

in the end of the pen body and providing, in effect, a continuation of the external contour of the pen body. The end wall 122 is formed with an ink inlet opening 123 below the center thereof for the purpose of admitting ink into the interior of the pen as hereinafter more fully described.

The interior of the forward body section 100 provides an ink reservoir chamber or space in which is located a capillary filler-and-reservoir element 125 (hereinafter called a "filler element") which is adapted to be filled with ink by capillary action when the writing end of the pen is inserted in a supply of ink. The capillary filler element 125 has a plurality of passages or ink storage spaces or space portions therein suitably connected and adapted to be placed in communication with the supply of ink and to draw ink therein by capillary action. The capillary ink spaces are of such capillarity that they retain ink therein by capillary action when the pen is not in use and permit ink to be withdrawn therefrom when the pen is used in writing. The capillary storage spaces, together with the ink feed means connected between these spaces and the nib slit maintain the ink in the pen entirely under capillary control at all times and there is no free body of ink within the pen subject to influences which tend to cause leakage in fountain pens of the type having a reservoir containing a free body of ink.

The capillary filler element 125 includes a plurality of elongated partitions or fins 126 forming wall elements extending longitudinally of the pen body and disposed in generally radial arrangement to define therebetween a plurality of longitudinal spaces or passages 129 of generally wedge-shaped cross-section and of capillary width. The fins 126 terminate inwardly short of the center of the capillary filler element 125 to define a longitudinally extending central space 132 which provides intercommunication between all of the capillary spaces or space portions 129.

The capillary spaces 129 are each connected in ink feeding relation with the nib slit 111 by a feed element 130 which is so formed as to provide a plurality of capillary passages extending from the inner open longitudinal edges of the spaces 129 to the nib slit 111. The feed element 130 may be formed in various ways but preferably is formed as a wick consisting of a large number of fibers or threads of suitable material. In one specific embodiment of my invention excellent results were obtained by forming the wick as a bundle of essentially parallel spun glass filaments. Other materials which have been found suitable for forming the wick are animal or vegetable fibers, or nylon and in one embodiment the wick was formed of 20 denier nylon threads each consisting of 20 filaments. Preferably the material should be one which is not absorbent and which is not detrimentally affected by inks of the types used with the pen. The feed element extends preferably throughout the entire length of the capillary filler element and at the forward end thereof projects beyond the end of the capillary filler element and into direct contact with the underside of the pen nib adjacent the slit therein. Preferably the feed element is of sufficient length so that it is held against the underside of the pen nib and capillary passages are maintained in ink feeding relation with the nib slit.

Means are provided in the pen of my invention for venting the interior to atmosphere to maintain the air substantially at atmospheric pressure

thereby permitting the pen to fill rapidly by capillary action and permitting ink to be withdrawn under capillary control when the pen is used in writing. In addition, the equalization of pressure between the exterior and interior of the pen renders the pen substantially insensitive to changes in atmospheric pressure whereby in the event that atmospheric pressure should be reduced, as for example, when the pen is carried to a high elevation there is no tendency for ink to be forced from the pen as often occurs in the case of fountain pens wherein ink is retained within the pen by the maintaining of subatmospheric pressure within the ink reservoir. Similarly, the equalization of pressure prevents any tendency of the ink flow to be blocked during writing such as might occur upon an increase in atmospheric pressure.

Equalization of pressure between the interior and exterior of the pen is effected by providing an air pressure equalizer or vent passage which extends longitudinally of the capillary filler element preferably throughout the length thereof and communicates with all of the capillary ink spaces in the capillary filler element. The vent passage preferably is provided by so forming the capillary filler element that a generally wedge shaped passage 131 is provided which extends inwardly into communication with the central space 132. The vent passage 131 communicates with ink of the cells in a manner hereinafter described in detail. The vent passage 131 extends to the space forwardly of the filler element which is in communication with the atmosphere through the nib pierce 110 and the air inlet port 115. In certain cases it may be found desirable to provide a space within the interior of the pen body at the rear of the capillary filler element which serves to connect the rear ends of each of the capillary spaces 129 with the rear end of the air vent passage 131.

In order to provide the maximum ink capacity in a pen of any predetermined size, the ratio of total void space to the total volume of space within the ink reservoir is made as great as possible, consistent with the requirement that the capillary spaces be of suitably small width to provide the necessary capillarity to draw ink into these spaces and retain it therein by capillary action. Accordingly, the fins forming the capillary filler element are made as thin as practicable consistent with mechanical strength and rigidity thereby providing as great a number as possible of capillary spaces or cells of predetermined wall-to-wall width or thickness.

It will be understood that the narrower the cells the greater will be the capillarity exerted thereby on ink contained in the cells. The cells are made of such width that they exert sufficient capillarity to draw ink therein during filling to fill the cells substantially throughout their entire lengths and to retain ink therein when the pen is not in use. The capillarity of the cells, however, is not so great as to prevent ink from being withdrawn from the cells by capillary action established between the writing tip of the nib and a writing surface when the nib is placed in contact with the writing surface during writing. In order to insure that ink will be drawn into the capillary cells during filling, when the end of the pen is inserted in a supply of ink, it is necessary that the cells have such capillarity as will lift the ink substantially to the top-most portion of the cells, at least at the narrowest portion adjacent the feed element, when the pen is held in filling position. The width of each portion of each cell at any point

throughout the length of the cell theoretically should be such as to provide the necessary capillarity to lift a column of ink to that particular point of the cell during filling. However, for convenience in manufacturing, the cells are not dimensioned so that they increase in capillarity continuously from the writing end of the pen toward the rear end of the pen; but the capillary filler element is formed in a plurality of longitudinally adjacent sections in each of which the cells are of greater capillarity than the section next nearer the writing end of the pen.

This progressive increase in capillarity may be accomplished conveniently in a capillary filler element of the construction illustrated in Fig. 5 by providing a greater number of cells in the sections in which it is desired the cells shall have the greater capillarity. For example, the capillary filler element 125 is formed by three sets of fins 126, 127, and 128, the fins in the three sets being of different lengths. Thus, the cells provided in the forward section of the capillary filler element are defined only by the long fins 126; the cells provided in the second or intermediate section of the capillary filler element are defined by the long fins 126 and the fins 127 of intermediate length and the cells formed in the third or rear section of the filler element are defined by the fins 126, 127 and the short fins 128.

The foregoing will be understood somewhat more clearly from an inspection of Fig. 8 of the drawings and from the following description of one mode of forming the filler element.

The capillary filler element may be formed in various ways, it being understood that the construction is such that the fins are suitably retained in radially extending position with their inner ends suitably spaced and their outer ends also spaced but at a greater distance than the inner ends so that the true radial arrangement and desired spacing of the fins is preserved. Preferably the fins are equally spaced in order that the cells all are of similar cross-sectional dimension. The fins may be formed of any suitable thin sheet material, which has sufficient mechanical strength and rigidity, which is not deteriorated by the ink, and which does not adversely affect the ink. The fins may be formed either from a suitable metal foil as, for example, silver, or from a plastic material, such as "Vinylite"; for convenience in forming the filler element, I prefer to use a plastic.

One convenient mode of forming the fins into a filler element comprises arranging strips of thin plastic material of suitable dimensions in a repeated series, each of which series includes a strip of short length, a strip of intermediate length, a second short strip, and a long strip. The strips are disposed in parallel arrangement and spaced by spacing elements 135 of suitable thickness to provide the desired spacing and a width approximately equal to the desired width of the fins in the finished filler element. The strips are of sufficient width to extend beyond the side edges of the spacing members 135 a distance equal to at least the thickness of three spacing members and the corresponding strips. With the strips and spacing members held in compact condition the extending marginal portions of the strips are bent over at approximately 90° to the main or body portions of the strips so that each marginal portion overlies the bent over marginal portions of the next several strips, as illustrated somewhat diagrammatically in Fig. 7 of the drawings. Where the strips are of plastic material, the bent over marginal portions may

then be united by the application of sufficient heat to cause them to fuse to one another and to take a permanent set in the bent over position. Thus, there is provided a unitary structure in which the bent over and overlapping marginal portions of the strips form, in effect, a substantially continuous backing web from which the body portions of the strips project substantially perpendicularly and form spaced parallel flanges or fins.

I prefer to attach to the outer face of the aforesaid web a separate backing sheet 136 which is fused to the web and thereby provides added strength to the structure and insures the unitary nature of the structure. That is to say, by providing a single unitary backing sheet, several strips will be retained in connected condition even in the event that one or more of the strips should not originally be securely connected to the adjacent strips or should later become disconnected. The backing sheet 136 is applied to the bent over marginal portions and is fused thereto. Preferably the fusing is accomplished by applying heat and pressure simultaneously which serves to "iron" over the marginal portions and provide a relatively smooth and flat backing web. The spacers 135 are then removed. The assembled structure resulting from the foregoing operations is illustrated somewhat diagrammatically in Figs. 8 and 9 of the drawings.

The assembled structure is then "rolled" into cylindrical form with the free ends of the fins innermost and the backing web outermost. The inner ends of the fins at the two side edges of the structure are brought into abutment but the outer edges do not come together but are spaced apart a sufficient distance to provide the vent passage 131 as illustrated in Figs. 3 and 4. It will be understood that the assembled structure may be held in rolled cylindrical form in any desired manner but preferably the dimensions of the filler element are such that it snugly fits within the ink reservoir space and held in the desired cylindrical form when thus inserted therein.

Preferably, prior to rolling the structure into cylindrical form the feed element or wick 130 is laid onto the free ends of the fins and the structure rolled around the feed element to substantially enclose the latter when the filler element is rolled as above described.

It will be seen from the foregoing that the attachment of the marginal portions of the fin-forming strips to each other insures that the fins are suitably spaced from each other at their outer edge portions. Means preferably are provided for spacing the inner edge portions of the fins in order to maintain the desired spacing when the structure is rolled into cylindrical form. Such means preferably takes the form of corrugations 137 formed on the inner edges of alternate fins which corrugations are adapted to abut the inner edge portions of adjacent fins when the structure is rolled into cylindrical form.

The capillary filler element 125 is so formed that its external contour conforms substantially with the internal shape of the interior of the forward body section whereby the capillary filler element is snugly held in the pen body and the maximum utilization of space within the pen body is insured. Thus, when the forward end of the reservoir is tapered, and the filler element extends into such tapered portion, that end of the filler element is similarly tapered.

This may be accomplished in any suitable man-

ner, as, for example, by providing a plurality of notches in the backing sheet to provide a series of tongues therein and by causing the forward end of the corresponding groups of fin-forming strips to converge so the strips in each group may be attached to the corresponding tongue when the strips are attached to the backing strip.

The capillary filler element is of such length that it terminates short of the extreme forward end of the pen body and therefore a space 138 is provided between the forward end of the capillary filler element and the floor 122 of the end piece, which accommodates the projecting end of the feed element 130. This projecting end is brought into abutment with the underside of the nib and the inner face of the floor 122 and the capillary passages defined by the feed element are placed in ink-feeding communication with the nib slit.

Communication between the air vent passage 131 and each of the several capillary cells 129 is provided, preferably at spaced points throughout the length of the capillary filler element, by annular passages 139 which are spaced longitudinally of the capillary filler element. Preferably the passages 139 are formed by cutting grooves in the capillary filler element which grooves extend through the backing sheet and web and are cut into the fins at their outer marginal portions thereby providing relatively free air communication between the air vent passage 131 and the several capillary spaces 129.

The pen is filled by inserting the writing end of the pen into a supply of ink preferably a sufficient depth to immerse the ink inlet opening 123 and place the capillary passages 129 in the filler element 125 in direct feeding relation with the supply of ink. Ink is drawn into the filler element 125 and also the feed element 130 by capillary action and rises therein by capillary action to fill the capillary spaces therein.

Air which is in the capillary spaces 129 is forced therefrom by the incoming ink and finds its way out of the pen through the circumferential vents 139, air vent passage 131, the nib pierce 110 and the air port 115. If desired, an air outlet passage and port similar to those shown in Fig. 17 and described hereinafter may be provided in the rear body section 101 for additional venting of the pen. Where the end of the pen is inserted into the supply of ink to such an extent that the air port 115 is below the level of the ink such manipulation will not prevent filling of the pen inasmuch as the capillary force exerted on the ink tending to raise it in the capillary filler element is sufficient to overcome the head of ink above port 115 in the ink supply and cause air to bubble up through the ink supply. However, it may be preferable to open the rear port by slightly unscrewing the end section 101 during filling.

Even though one or more of the cells should for any reason become blocked or fail to fill, the remaining cells will fill, owing to the fact that each of the cells is placed in direct communication with the ink supply. However, owing to the construction of the cells, there is virtually no possibility of any of the cells becoming blocked, as for example by the formation of an air bubble which if allowed to form in the cell might prevent ink from being drawn upwardly in that cell. The present invention substantially eliminates any possibility of an air bubble forming in any of the cells and causing an "air lock." Each of the cells is of wedge-shaped cross-section and

therefore the inner edge portion of the cell is narrower and of greater capillarity than the outer portion of the cell. Accordingly, ink tends to rise along the inner portion of each cell in advance of the ink at the outer portion of the cell. Thus, if an air bubble should tend to form at any portion of the cell, the ink would rise along the inner portion of the cell past such point and establish a continuous body of ink longitudinally of the cell thereby breaking up any such incipient air bubble.

In writing, when the point of the pen nib is placed in contact with the writing surface, the ink which is held in the nib slit by capillarity is withdrawn therefrom by the capillarity established between the nib and the writing surface, this capillarity being sufficient to overbalance the capillarity of the capillary system within the pen which holds the ink in the pen. The pen nib slit has a greater capillarity than the feed element 130 and draws ink from the latter to replace ink withdrawn from the nib slit. In a similar manner the capillary passages in the feed element 130 have a greater capillarity than the capillary cells of the filler element and thus withdraw ink from the latter to maintain the feed element 130 in substantially saturated condition, at least to the height above the writing end of the pen to which ink stands in the several capillary cells. Inasmuch as the capillarity of the several cells increases inwardly toward the feed element 130, ink is drawn inwardly of the pen and toward inner side edges of the capillary cells at which point it is drawn into the feed element 130. The capillary cells 129 in general are emptied from the rear toward the front end of the pen and therefore ink stands in the forward end of the cells until they are substantially emptied.

Because of the fact that each cell has an increasing capillarity toward the inner side edge portion thereof which is in communication with the feed element and since the passages in the feed element have greater capillarity than the cell, ink is drawn from the cell toward and into the feed element and is delivered thereby to the nib. Thus, even after long periods of nonuse, during which the pen may be maintained in inverted position, a continuous column of ink will extend from the cells to the nib and the pen will remain in condition for substantially instant writing. This cell construction also insures substantially complete withdrawal of ink from the cells since the ink is drawn from the outer portions of lesser capillarity toward the inner portions of greater capillarity and thence into the feed element. In addition, each cell is connected substantially throughout its length directly to the feed element which construction insures that ink will be drawn directly from the cells into the feed element throughout the principal portion of the length of the feed element. This contributes toward certainty of feed and substantially complete withdrawal of the ink from the cells. Moreover, there is substantially no possibility of air locking of ink in the cells such as might otherwise prevent substantially complete withdrawal of ink and thus reduce the effective capacity of the pen.

Air to replace ink which is withdrawn in writing enters the pen through the air port 115, the nib pierce 116 and the air passage 131. From the air passage 131 air is drawn into the cells at the rear ends thereof and also by way of the circumferential air passages 139. Thus, ink is fed to the nib under capillary control at all times and

the pen is not subject to any blocking of the flow by reason of a decrease in the air pressure within the pen.

In one practical embodiment of a fountain pen employing the invention as illustrated in Figs. 1-5 of the drawings and having overall exterior dimensions approximately equal to those of a conventional fountain pen, excellent results were obtained by employing a capillary filler element having overall length of approximately 2" with its forward end extending to the nib pierce and approximately 1/2" from the writing end of the nib. The filler element was composed of 83 fins each 0.001" thick and approximately 0.120" wide. The overall diameter of the capillary filler element was approximately 0.320" and the central space was approximately 0.080" in diameter; the width of the air vent at its outer portion was approximately 0.070". The fins of the longest series were approximately 2" in length, the fins of the intermediate series were approximately 1.40" in length and the fins of the shortest series were approximately 1.05" in length. There were 20 fins in the longest series, 21 fins in the intermediate series and 42 fins in the shortest series. The capillary cells in the forward section of the capillary filler element each had an outer cell thickness of approximately 0.044" and an inner cell thickness of approximately 0.011"; the cells in the intermediate section of the filler element had an outer cell thickness of approximately 0.021" and an inner cell thickness of approximately 0.005". The capillary cells in the rear-most section of the capillary filler element had an outer cell thickness of approximately 0.010" and an inner cell thickness of approximately 0.002".

The pen had a refill capacity of approximately 1.4 grams of ink, that is, upon repeated filling and writing out, the pen upon each refilling operation took on approximately 1.4 grams of ink.

It will be understood that the present invention is not limited to the dimensions above stated and it will be understood that variations may be made in the dimensions given without departing from the invention.

In certain cases it may be found preferable, instead of forming the capillary filler element from a plurality of fins of different lengths, as above described, to form it in a plurality of separate but abutting sections in each of which there are a different number of fins providing a different number of capillary cells of correspondingly different capillarity. That is to say, the several sections forming such capillary filler element define cells of different capillarities, the cells in the rearwardmost section being the most numerous and of the greatest capillarity and the cells in the forwardmost section being the fewest and having the least capillarity and the cells in the intermediate section or sections having intermediate capillarities progressively increasing from the forward toward the rearward end of the pen.

A pen embodying the foregoing type of capillary filler element is illustrated in Figs. 11-14 of the drawings, to which reference now is made. The pen may embody any suitable type of casing or body but preferably the body includes a main or central section 140, a forward section 141, preferably tapering toward its forward end, an intermediate section 142, and a rear section 143; all of the sections preferably are connected by threaded joints, as illustrated. A friction ring 143 may be provided if desired at the juncture

of the central and forward sections for cooperation with a slip cap of known construction. The central and forward sections of the pen body are of generally hollow form and together define a chamber 144 adapted to receive either a capillary filler element or a cartridge structure of the type hereinafter described in detail and including a capillary filler element and feed.

The forward end of the forward body section 141 is provided with a bore 145 which extends through the forward end of the pen body and is adapted to receive a writing element which preferably takes the form of a pen nib 146. The pen nib may be of known form and includes a split cylindrical body portion 147 and a tapered writing end portion 148 provided with a pierce 149 and a slit 150. For the purpose of permitting flexing of the writing end of the pen nib and for maintaining a body of ink adjacent the nib pierce and slit, whereby the same are always maintained filled with ink and in condition for instant writing, a slight space 151 of capillary thickness is provided above the pen nib. This space may be provided by forming a counterbore 152 in the forward end of the pen which counterbore is of slightly greater diameter than the pen nib.

A capillary filler element is disposed in the chamber 144, which filler element is constituted by a plurality of sections 155, 156 and 157. While three such sections are shown in the present application it will be understood that any suitable number might be provided and that the capillary filler element may consist of two, three or more sections as desired. Each of the sections of the capillary filler element is formed preferably in a manner generally similar to the capillary filler element 125 except that the fins in any one section are of the same length and therefore all of the cells in any section are the same. That is, the fins 158 forming the section 155 are all of the same length. In a similar manner the fins 160 forming the section 157 are all of the same length although preferably they are of a different length from the fins 158.

A feed element 161, which may be generally similar to the feed element 130 shown in Fig. 1 of the drawings, extends centrally of the several sections 155, 156 and 157 of the capillary filler element. Preferably the feed element 161 is formed as a single element extending substantially throughout the length of the entire capillary filler element and has a forward portion 162 which extends into abutment with the pen nib adjacent the slit 151.

For the purpose of retaining the several sections of the capillary filler element and the feed element in assembled relation I preferably provide an inner or cartridge casing member 163 formed of suitable material such as a plastic or thin metal, and preferably the latter. The cartridge casing 163 is shaped and dimensioned to snugly receive the several sections of the capillary filler element and to fit snugly within the pen body. Accordingly, the cartridge casing 163 may be tapered at its forward end but preferably it is formed with a plurality of cylindrical sections 164 and 165 of progressively decreasing diameters, suitably dimensioned so that they fit within the tapered forward body section 141. The sections 164 and 165 are of cylindrical rather than tapered form thereby permitting the use of capillary filler sections of cylindrical shape which as will be understood are somewhat easier to manufacture than sections of tapered form. The several sec-

tions 155, 156 and 157 are made to fit snugly in the corresponding sections of the cartridge casing and thus are held in proper position. In order to insure that the capillary cells in each of the sections of the filler element are maintained in communication with the cells of the next adjacent section, the sections are held in firm abutment. This is insured by making the sections 155 and 156 of slightly greater length than the corresponding portions of the casing so that these sections project rearwardly from such portions. The screen 172 abuts the rear section 157 to maintain all the sections in abutment.

The cartridge casing 163 is provided with a forward, generally cylindrical extension 166 of reduced diameter adapted to extend through the cylindrical nib 146 which extension serves to confine the portion of the feed element 161 which extends beyond the forward end of the capillary filler element and at the same time to retain the forward portion 162 of the feed element in contact with the underside of the nib. The extension 166 is provided with a forward end wall 167 conforming generally to the contour of the pen body at this portion and which serves to confine the end 162 of the feed element. An opening is provided in the upper wall portion of the extension 166 at the forward end thereof which permits the forward portion 162 of the feed element 161 to abut the underside of the pen nib 146.

The cartridge casing 163 is provided with an inwardly projecting, grooved portion or bead 168 which extends preferably throughout the length of the casing 163. The bead 168 thus provides between the casing 163 and the adjacent portion of the pen body a passage 169 which extends forwardly to an air port 170 and which extends rearwardly to the end of the cartridge. The passage 169 thereby constitutes an air vent passage which is in communication with the exterior of the pen through the port 170 and is in communication with the rear ends of the capillary cells defined by the capillary filler element through the space 171 rearwardly of the capillary filler element. Preferably a perforated plate or screen 172 extends across the rear end of the cartridge casing 163 for the purpose of retaining the capillary filler element in the casing and is suitably held in place, as by abutment of the end section 142. The screen is sufficiently open to permit air to pass freely therethrough between the rear ends of the capillary cells and the chamber 171.

The bead 168 may be utilized to maintain the desired spacing between the endmost fins of each section of the capillary filler element to thereby provide an air vent passage 173 which extends along each of the sections of the capillary filler element.

The feed section 165 of the inner casing 163 is provided with an end wall 174 formed with a plurality of openings 175 and the adjacent end wall of the chamber 144 in the forward body section is forwardly inclined to provide a space 176 which is in communication with the bore 145. A plurality, preferably two grooves 177 and 177a of U-shaped cross-section are formed in the walls of the bore 145 and extend from the space 176 to the end of the body; thus ink may enter the interior of the casing 163 through the forward end of the pen during filling.

In filling the pen the forward end of the pen is inserted in a supply of ink preferably of sufficient distance to immerse the end of the pen at least as far as the ends of the fins 158. Ink

is drawn into the pen through the counterbore 152, the passage 177, the space 176 and the openings 175 and thence into the capillary filler element; ink also is drawn into the pen through the passage 177a above the nib 146 and into the space 176. Ink rises in the capillary spaces in a manner similar to that described hereinbefore. Air which is in the capillary spaces at the beginning of the filling operation is expelled by the incoming ink and passes out of the capillary spaces through the screen 172, the chamber 171 and thence through the air vent passage 169 and out through the air port 170.

In writing, ink is drawn to the nib from the capillary spaces in a manner generally similar to that described in connection with the embodiment of the invention illustrated in Fig. 1 of the drawings. Air to replace ink which is withdrawn in writing is drawn into the pen through the air port 170 and passes to the capillary cells in a direction reverse to that in which air is expelled from the cells during filling.

Instead of forming the feed element 161 as a fibrous wick, as illustrated in Fig. 12 of the drawings, this may be formed as a solid bar as illustrated in Figs. 15 and 16. The feed element 173 may be formed of any suitable material but preferably is formed of a plastic such as "Lucite" (methyl methacrylate resin). This member preferably is formed with an elongated cylindrical body portion 179, adapted to extend substantially throughout the length of the capillary filler element, and a forward extension 180 which may be of slightly greater diameter than the body portion 179 and which is adapted to fit snugly in a forward tubular extension 166a of the inner casing 163a and an enlarged head 180a adapted to abut the forward end of the extension 166a to position the feed element 173 within the casing 163a. The feed element 173 is formed with a feed slot 181 preferably of capillary width, extending throughout its length and preferably at least two such slots are provided. The slots 181 provide capillary ink feed ducts which serve to deliver ink by capillary action from the capillary filler element to the nib in a manner generally equivalent to that in which the feed element 161 serves to feed ink to the nib as above described. The ink feed slots 181 extend at their forward ends to the underside of the nib and are in communication with all of the capillary cells by the provision of transverse feed slots 182 of capillary width which are arranged in a spaced series longitudinally of the feed element 173 and which extend circumferentially around the feed element 173 and intersect the longitudinally extending feed slots 181.

A further embodiment of the invention is illustrated in Figs. 17 to 23 of the drawings in which the capillary filler element is constituted by a plurality of thin sheets of suitable material rolled into convolute form and defining between adjacent convolutions thereof spaces of capillary width or thickness extending longitudinally throughout the capillary filler element.

Referring particularly to Fig. 17, the pen includes a body of any suitable form and having, for example, a forward body section 185 and rearward body section 186 detachably secured thereto. The forward body section is formed with a bore or chamber 187 defining an ink reservoir space and having a dished forward end wall 188. A bore 189 leads forwardly from the chamber 187 and communicates with a counterbore 190 extending through the forward end of the pen body

and which preferably is provided with an enlarged or counterbored portion 191 at the forward end thereof.

A writing element, which preferably takes the form of a slitted nib 192, is seated in the counterbore 190 and a shoe 193 cooperates with the nib in a manner generally similar to that described in connection with the form of pen shown in Fig. 1; in the present embodiment, however, the nib and shoe are held in position solely by friction.

Leading from the chamber 187 and through the forward end of the pen are a plurality, and preferably two, filling slots 194 and 194a of generally V-shaped cross section which provide passages for the entry of ink into the pen during filling as hereinafter more particularly described.

Disposed in the chamber 187 is a capillary filler element formed by rolling together a plurality of thin walled sheets of suitable material such as metal or plastic having a surface sufficiently wettable by inks of the type customarily used to exert the desired capillary attraction on the ink. The material is sufficiently flexible to permit it to be rolled into convolute form and sufficiently rigid to maintain its shape and position. Excellent results have been obtained by forming the sheets from materials such as silver foil, gold foil or cellophane although I prefer to use a metal for reasons which will hereinafter appear.

The sheets are rolled or wrapped together into convolute form to define therebetween spiral spaces or space portions of capillary thickness defining capillary ink storage spaces, the various portions of the sheets thus serve as wall elements defining capillary spaces or space portions. In order to provide spaces of lesser thickness and greater capillarity at the portion of the filler element more remote from the writing end of the pen than at the forward end of the capillary filler element sheets having differing widths are employed as illustrated particularly in Fig. 22. By way of example, one sheet 195 has a width such that it extends the full length of the capillary filler element and the turns of this sheet define capillary spaces 196 having the greater thickness. A second sheet 197 of intermediate width is provided and the spaces 198 between the turns of this sheet and the long sheet 195 are of intermediate thickness. Where it is desired to provide capillary spaces of three different thicknesses, two additional sheets 199 are provided which define with the sheets 195 and 197, respectively, capillary spaces 200 which are of the least thickness. In forming the capillary filler element the four sheets are stacked with their rearward longitudinal edges in alignment and are rolled into a spiral as illustrated in Figs. 17 and 22.

It will be understood that instead of forming the filler element from a plurality of sheets as just described, it may be formed from a single sheet, suitably shaped so that when rolled into convolute form it defines spaces or cells generally equivalent in form and arrangement to those defined by the plurality of sheets, except that but a single spiral passage is provided in each section of the filler element.

For the purpose of maintaining the desired spacing between the consecutive turns of the several sheets 195, 197 and 199, each of the sheets is formed with a plurality of spaced projections 201 which, when the sheets are rolled into convolute form, abut the adjacent convolutions of the sheet or the adjacent sheet. The projections 201 are formed of such heights that they provide

the desired spacing. Thus the projections 201a in the sheets 199 and in the corresponding portions of the sheets 195 and 197 are the lowest. The projections 201b formed in the sheet 197 and in the corresponding portion of sheet 195 are of intermediate height and the projections 201c formed in that portion of the sheet 195 which is rolled upon itself are of the greatest height. Preferably the projections 201 are provided by forming them from the material of the sheet itself. While the projections may be formed as mere indentations, I prefer to form them by puncturing the sheet thereby providing openings 202 extending through the sheet which openings serve to place the spaces on either side of the sheet in communication, thus permitting relatively free flow of ink or air between adjacent spaces. If desired, the projections may be formed as imperforate indentations (not shown) and separate perforations (not shown) provided in the sheets intermediate the indentations.

For the purpose of conducting ink by capillary action from the capillary cells in the filler element to the nib, a feed element 203 is provided which preferably takes the form of a wick similar to the wick 130 described hereinabove. The feed element 203 preferably extends centrally of and throughout the length of the capillary filler element and through the bore 189 and into the space defined by the nib and shoe. The forward end of the wick is maintained in abutment with the slit of the nib 192 and the capillary passages in the wick thus are connected in ink feeding relation with the nib slit. The feed element 203 preferably is assembled with the capillary filler element by placing it against the marginal portions of the sheets 195, 197 and 199 when they are assembled in flat form and the sheets are then rolled around the feed element which may serve as a core aiding in the rolling or wrapping of the sheets.

The capillary passages in the feed element 203 are in ink feeding relation with the innermost capillary spaces by reason of the openings in the convolutions of the several sheets immediately surrounding the feed element 203. The outer convolutions of the capillary spaces are in communication with the inner convolutions of the spaces through the openings in the intervening convolutions of the sheets. Moreover, by reason of the spiral form of the capillary spaces the several convolutions of a single space are connected and in communication in a circumferential or a spiral direction.

The capillary filler element may be maintained in the chamber 187 in any suitable manner and by way of example there is illustrated a ring or washer 204 of relatively soft resilient material, such as rubber, abutting the rear end of the capillary filler element and itself maintained in position by abutment with the forward end wall of the rear body section 186.

For the purpose of venting the interior of the pen body, in order to maintain the air pressure therein substantially at atmospheric pressure I provide preferably a port 205 in the rear body section which at one end is in communication with the chamber 187 and at its other end terminates adjacent the joint between the body sections whereby when the latter are slightly unscrewed the port is opened to the atmosphere. The pen also may be vented through the ink filling openings 193 and 194 at its forward end and in certain cases it may not be necessary to provide any vent passage at the rear end of the

chamber 187 although this is preferable in order to insure rapid filling.

In filling the pen, the end of the pen is inserted in a supply of ink preferably a sufficient distance to place the forward end of the capillary filler element 194 below the level of the ink. Ink enters the pen through the filling passages 193 and 194 and enters the capillary spaces 196 at their forward end. Ink rises in the capillary spaces by capillary action and completely fills the spaces to the top or rear end of the capillary filler element. Since the forward ends of all of the capillary spaces are in communication with the space 206 between the forward ends of the capillary filler element and the forward end wall 188 ink enters all of the capillary spaces simultaneously and rapid filling takes place. Air which is in the capillary spaces at the beginning of the filling operation is forced out by the incoming ink and, when a rear end vent is provided, passes out through such vent; where no rear end vent is provided the air is forced out through the forward end of the pen and bubbles up through the body of ink in which the pen is inserted. Inasmuch as all of the capillary spaces are in communication with adjacent spaces and since each space has an extensive cross-sectional dimension in a circumferential direction there is little, if any, possibility of an air bubble being trapped in any portion of the capillary space in a manner which would tend to block or retard the filling to any material extent.

In writing, the capillarity established between the writing tip of the nib and the writing surface draws ink from the nib which is immediately replaced by ink from the feed element 203. The latter in turn is maintained in substantially saturated condition by reason of its being in ink feeding communication with the innermost capillary surfaces of the several sections of the capillary filler element. It will be understood that the capillarity of the feed element 203 is greater than that of the smallest spaces 200 of the capillary filler element and the capillarity of the nib slit is still greater, thereby insuring that ink will be drawn to the nib slit by capillarity so long as any ink remains in the pen.

The capillary filler element is so constructed that the capillarity of the spaces 196 is sufficient to lift ink to the height of these spaces above the supply of ink and to maintain ink in these spaces at all times but insufficient to prevent ink from being withdrawn therefrom when the pen is used in writing. In a similar manner the capillary spaces 198 have sufficient capillarity to lift ink to the height of these spaces above the supply of ink, and in a similar manner the spaces 200 have the greatest capillarity which is sufficient to raise ink to the upper end of the capillary filler element during filling.

If desired, the spiral capillary filler element instead of being formed of a plurality of sheets of different widths may be formed in a plurality of sections each of which comprises a single sheet. A filler element 207 of this construction is shown in Fig. 24 and includes a plurality, preferably three, sections 208, 209 and 210. The forward section 208 is formed of a single sheet having projections 211 which space the consecutive turns of the sheet the desired distance apart to provide a single capillary space 214 of spiral form. The sheet 209 is formed with projections 212 of lesser height than the projections 211 and the sheet has a correspondingly greater number of turns so that while the section 209 is of the

same over all diameter as the section 208 the capillary space therein has a lesser wall-to-wall thickness. The rear section 210 is formed of a sheet having the lowest projections and the capillary space therein has the least wall-to-wall thickness. A feed element 203 which may be generally similar to that illustrated in Fig. 17 is provided and is engirdled by all of the three sections forming the capillary filler element.

A filler element formed from a single sheet as referred above is shown at 216 in Figs. 25 and 26. The sheet 216 (Fig. 25) from which it is formed has a straight rear edge 222 and a plurality of portions 220, 224 and 226 of different lengths measured in a direction from the edge 222. The sheet is rolled on a feed element 223, similar to the feed element 130 referred to above. The sheet portions 220 form short wall elements or portions 230 (Fig. 26), the portions 226 form wall elements or portions 232 (Fig. 26), of intermediate length and the portions 224 form long wall elements or portions 234 (Fig. 26) extending throughout the length of the filler element. The sheet is provided with projections 236, 238 and 240 respectively dimensioned and positioned for spacing the wall elements apart in the rolled filler element to form capillary spaces 242, 244 and 246, graded as to capillarity in a manner similar to that described above in connection with Fig. 17. The spacing projections are preferably formed similarly to the projections 201 (Fig. 23), being provided with apertures 248. A complete pen embodying the just-described filler element is shown in Fig. 27 and is similar to the pen of Fig. 17 except in respect to the filler element.

From the foregoing it will be seen that the present invention provides a fountain pen of the capillary type having improved filling and ink feeding characteristics. The pen has a relatively high write-out and refill capacity. The feed of ink to the nib is positive and the pen is ready at all times for instant writing. The pen is fully vented and the capillary system is such that the pen is not subject to air locking either during filling or during writing, but may be completely filled and may be written out substantially completely. The pen is simple and rugged in construction and may be easily manufactured and will operate for a long period of use without adjustment or repair.

I claim:

1. A fountain pen comprising a pen body having an ink reservoir section, a writing element carried at one end of said pen body, a capillary filler-and-reservoir element disposed in said reservoir section and having a plurality of wall elements defining a plurality of capillary space portions each extending longitudinally of said reservoir section, there being a greater number of wall elements defining space portions of greater capillarity, transversely of said reservoir section, in the portion of said filler-and-reservoir element most remote from said writing element than in the portions nearer said writing element, and ink feed means having a capillarity at least as great as that of said space portions most remote from said writing element connecting said capillary space portions in ink feeding relation to said writing element.

2. A fountain pen comprising a pen body having an ink reservoir section, a writing element carried at one end of said pen body, capillary filler-and-reservoir means in said reservoir section including a plurality of thin-walled partition members disposed in radial arrangement and

extending longitudinally of said reservoir section and defining therebetween a plurality of radially arranged, longitudinally extending capillary cells, there being a greater number of partition members in the portion of said reservoir section most remote from said writing element than in the remaining portion thereby providing a greater number of cells of greater capillarity in said most remote portion than in said remaining portion, and capillary ink feed means connecting said capillary cells in ink feeding relation to said writing element.

3. A fountain pen comprising a pen body having an ink reservoir section, a writing element carried at one end of said pen body, a capillary filler-and-reservoir element in said reservoir section including a plurality of longitudinally extending walls having opposed portions mutually inclined and defining therebetween a plurality of capillary spaces, there being a larger number of walls in the portion of the capillary filler-and-reservoir element most remote from said writing element than in the portion nearest to said writing element and providing capillary spaces of greater capillarity than in said portion nearer to said writing element, and capillary ink feed means connecting said capillary spaces in ink feeding relation to said writing element.

4. A fountain pen comprising a pen body having an ink reservoir section, a writing element carried at the forward end of said pen body, a capillary filler-and-reservoir element in said reservoir section including a plurality of wall members disposed in opposed relation and defining therebetween a plurality of capillary ink storage cells extending longitudinally of said element, certain of said wall members extending throughout the length of said filler-and-reservoir element, and wall members intermediate said first wall members terminating short of the forward portion of said filler-and-reservoir element whereby the cells in the portion of the element remote from the writing element have a greater capillarity than in the portion nearer to said writing element, and ink feed means connecting said cells with said writing element.

5. A capillary filler-and-reservoir element for a fountain pen comprising a generally cylindrical web, a plurality of thin-walled fins carried by said web and extending radially inwardly therefrom to short of the center of said filler-and-reservoir element and defining plurality of longitudinally extending capillary spaces and a central space communicating with said capillary spaces, there being a greater number of fins in the rearward section of said filler-and-reservoir element than in the forward section providing a larger number of spaces of greater capillarity in said rearward section, and an ink feed element extending longitudinally of said central space providing a plurality of capillary ink feed ducts connected to said capillary spaces.

6. A capillary filler-and-reservoir element for a fountain pen comprising a generally cylindrical web, a plurality of thin-walled fins carried by said web and extending radially inwardly therefrom to short of the center of said filler-and-reservoir element and defining plurality of longitudinally extending capillary spaces and a central space communicating with said capillary spaces, there being a greater number of fins in the rearward section of said filler-and-reservoir element than in the forward section providing a larger number of spaces of greater capillarity in said rearward section, said filler-and-reservoir

element having an air vent groove extending longitudinally therealong, and a plurality of air vent grooves extending circumferentially therearound at longitudinally spaced portions thereof and communicating with said longitudinal air vent groove and with said capillary spaces.

7. The invention as set forth in claim 1 wherein said wall elements are provided by members rolled together to define between the convolutions thereof capillary ink storage cells of spiral cross-section.

8. The invention as set forth in claim 1 wherein said wall elements are provided by members of rolled form which define between the convolutions thereof capillary cells of spiral cross-section and the feed means includes a feed element centrally of said rolled wall members which extends substantially throughout the length thereof and to said writing element, and the feed element has a plurality of capillary passages connecting said capillary space portions in ink-feeding relation to said writing element.

9. The invention as set forth in claim 1 wherein said wall elements are provided by thin-walled sheets spirally wrapped upon each other to define between the convolutions thereof of capillary cells of spiral cross-section, certain of said sheets being of different widths than the others in a direction longitudinally of said capillary filler-and-reservoir element and said sheets being arranged to define a greater number of cells of greater capillarity in the portion of the capillary filler-and-reservoir element remote from said writing element than in the portions nearer the writing element.

10. The invention as set forth in claim 1 wherein said wall elements are provided by thin-walled sheets spirally wrapped upon each other to define between the convolutions thereof capillary ink storage cells of spiral cross-section, the several convolutions of said sheets having spacing projections extending therefrom and abutting adjacent convolutions.

11. The invention as set forth in claim 1 wherein said capillary filler-and-reservoir element is formed by a plurality of separate, juxtaposed, axially aligned sections, each section having spirally wrapped wall elements defining capillary cells extending longitudinally thereof, the number of cells and the capillarities of the cells in the respective sections progressively increasing from the forwardmost section to the rearmost section.

12. The invention as set forth in claim 1 wherein said filler-and-reservoir element is formed of a single member.

13. The invention as set forth in claim 1 wherein said filler-and-reservoir element is formed of a single member having wall elements of different lengths, and is rolled to define between the convolutions thereof a plurality of capillary spaces of spiral cross-section.

14. The invention as set forth in claim 4 wherein said filler-and-reservoir element is formed of a single member.

15. A capillary filler-and-reservoir element for a fountain pen of the type having a barrel with a writing element carried at its forward end, said filler-and-reservoir element comprising a plurality of elements defining a plurality of inter-connected capillary space portions forming ink storage cells each extending longitudinally of said filler-and-reservoir element, there being a greater number of wall elements defining a greater number of space portions of greater capillarity transversely of said filler-and-reservoir element in the

rearward portion of said filler-and-reservoir element than in the forward portion, and ink feed means having a capillarity at least as great as that of said space portions in the rearward portion of said filler-and-reservoir element connected to said space portions for connecting them with the writing element.

16. The invention as set forth in claim 15 wherein certain of said wall elements extend substantially throughout the length of said capillary filler-and-reservoir element, and wall element intermediate said first wall elements terminate short of the forward portion of said filler-and-reservoir element.

17. The invention as set forth in claim 15 wherein said wall elements are disposed in radial arrangement relatively to the longitudinal axis of said filler-and-reservoir element.

18. The invention as set forth in claim 15 wherein said filler-and-reservoir element includes a plurality of separate, juxtaposed axially aligned sections, each formed by a spirally wrapped sheet providing wall elements defining said space portions between the convolutions of said sheets.

19. The invention as set forth in claim 15 wherein said wall elements are formed by a plurality of sheets spirally wrapped upon each other to define said space portions between the convolutions of the sheets.

20. The invention as set forth in claim 15 wherein said wall elements are formed by a single sheet having portions of different lengths and spirally wrapped upon itself to define said space portions between the convolutions of the sheet.

21. The invention as set forth in claim 15 wherein said wall elements are formed by thin-walled material spirally rolled upon itself to define said space portions between the convolutions of said material and means including projections extending from said convolutions and abutting adjacent convolutions are provided for spacing said convolutions.

FREDERICK R. WITTNEBERT.

References Cited in the file of this patent

UNITED STATES PATENTS

Number	Name	Date
381,417	Pellinger	Apr. 17, 1888
674,943	St. Clair	May 28, 1901
798,250	Ballance	Aug. 29, 1905
1,336,119	Andersen	Apr. 6, 1920
1,413,476	Greenlaw	Apr. 18, 1922
1,603,142	Murray	Oct. 12, 1926
1,784,906	Oxhandler	Dec. 16, 1930
2,137,500	Morris	Nov. 22, 1938
2,187,528	Wing	Jan. 16, 1940
2,223,541	Baker	Dec. 3, 1940
2,235,453	Kirmes	Mar. 18, 1941
2,360,297	Wing	Oct. 10, 1944
2,427,243	Wahl	Sept. 9, 1947
2,430,023	Longmaid	Nov. 4, 1947
2,462,929	Zodtner	Mar. 1, 1949
2,522,553	Wittnebert	Sept. 19, 1950
2,522,554	Zodtner	Sept. 19, 1950
2,522,555	Bartell	Sept. 19, 1950
2,528,408	Zodtner	Oct. 31, 1950
2,554,654	Wittnebert	May 29, 1951
2,581,739	Wing	Jan. 8, 1952

FOREIGN PATENTS

Number	Country	Date
338,989	France	1904
25,155	Denmark	1919
127,562	Great Britain	1919
425,413	Great Britain	Mar. 11, 1935